

ELECTRIC BOLT LOCKS

EB-2501 SERIES

(Fail-Safe)(Power to Lock)

INSTALLATION INSTRUCTIONS

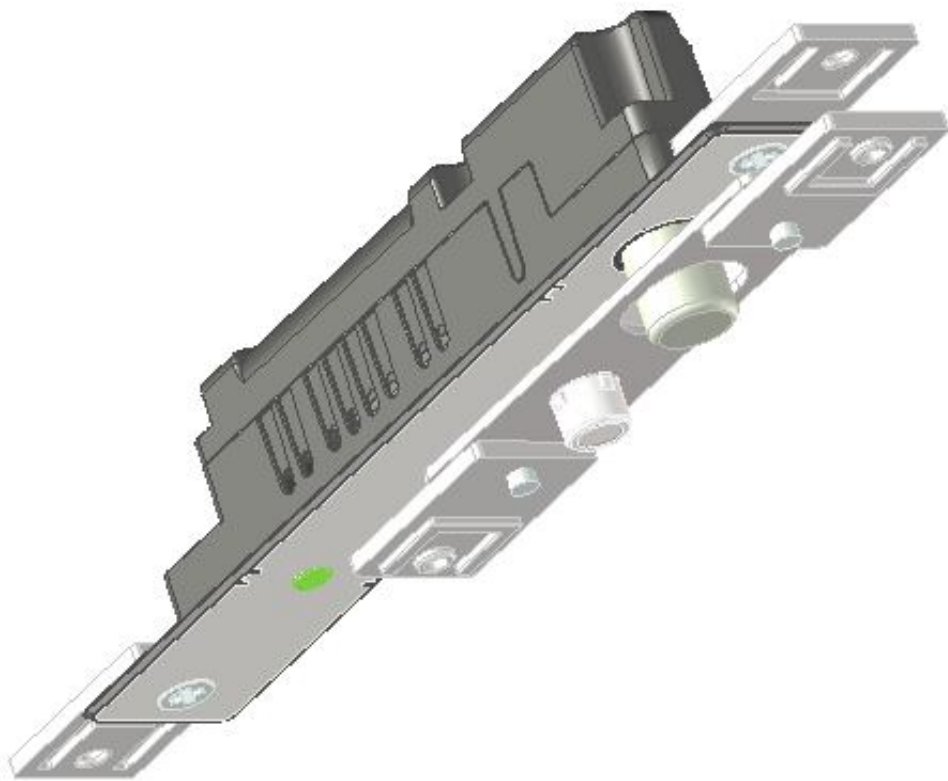

Contents

I.	Order Information	1
II.	Features & Functions	1
III.	Additional Functions	1
IV.	Specifications	1
V.	Contents	1
VI.	Wiring Diagram	1
VII.	Power input setting	
	A. 12VDC input setting	2
	B. 24VDC input setting	2
VIII.	Auto relocking timer setting	2
IX.	Indicators-LED and BUZZER	2
X.	System functions	2
XI.	Installation Diagram	
	A. Electric Bolt locks body	3
	B. Strike plate	3
	C. Dimension	4
	D. Installation Diagram	4

I. Order Information

M/NO.	Features & Functions				Additional Functions				
	Power Input	Remote Release	Time delay	Bicolor indicators	Auto-detective logical	LSS	DSS	Warning buzzer	Connect Bicolor
EB-2501M/LDAC	12/24VDC	○	○	○	○	○	○	○	○
EB-2501M/LDA	12/24VDC	○	○	○	○	○	○	○	×
EB-2501M/LD	12/24VDC	○	○	○	○	○	○	×	×
EB-2501U	12/24VDC	○	○	○	×	×	×	×	×
EB-2501UD	12/24VDC	○	○	○	×	×	○	×	×

II. Features & Functions

- Whole alloy housing
- Failsafe - Dual 12V/24V DC standard (self-regulating by 4-pin jumper)
- Bicolor indicators
- Auto-relocking timer setting: 0, 3, 6, 9 sec. for door locking time delay self-regulating by 2-pin dip-switch.
- Built-in exit switch input to unlock (If connected with latch type of exit switch, the bolt lock will be as N.O. without activated till switch off.)

III. Additional Functions (See “I. Order Information”)

- Auto-detective logical MCU
- Lock status sensor output (LSS): Indicates locked or unlocked bolt status (COM, NO, NC)
- Door position status output (DSS): Indicates door opened or closed position (COM, NO, NC)
- Warning buzzer: Indicates error status or forced entry. (BUZZER)
- Capability to extend the bicolor indicator by external indicators about 50cm

IV. Specifications

Item	Contents		Remarks	
Power Input and Tolerance	12VDC	24VDC	Stable PSU recommended	
Current Draw	Pull in	0.98A	0.55A	Changeable by power input and higher outer temp.
	Holding	0.24A	0.15A	Changeable by power input and higher outer temp.
Surface Temperature	< 40 °C		Room Temp. 25 °C	
DSS	Max.3W; Max.30VDC;Max.0.2A		COM,NO,NC	
LSS	Max.30VDC;Max 1A		COM,NO,NC	

V. Contents

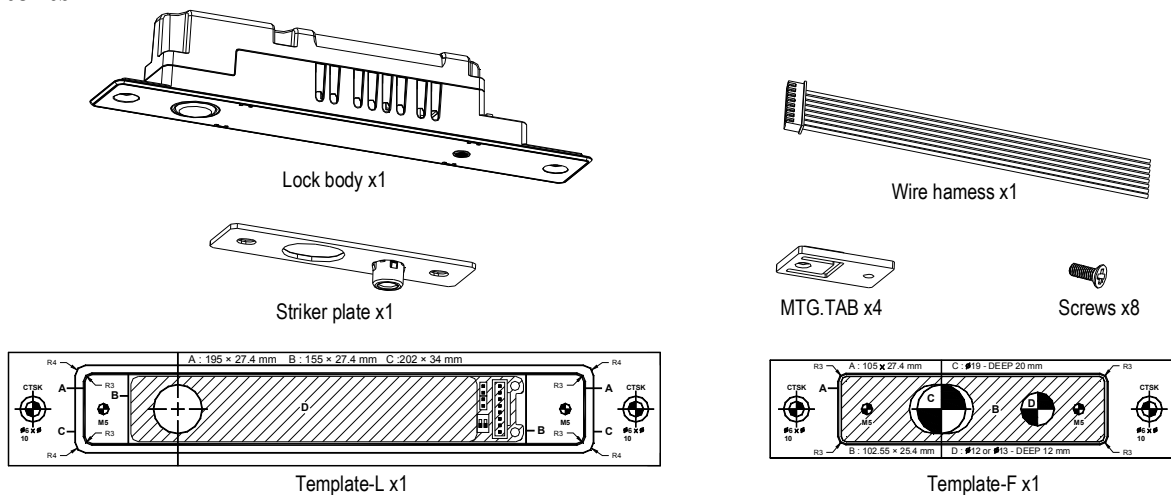

VI. Wiring diagram

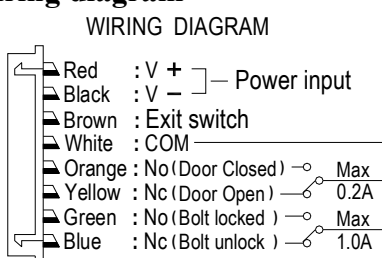

V+ (+12/+24VDC)	Red (22AWG)
V- (GND)	Black (22AWG)
Exit Switch	One close to Black (22AWG) One close to Brown (26AWG)
DSS (Door Status Sensor)	COM-White (26AWG) NO-Orange (26AWG) Door Closed NC-Yellow (26AWG) Door Open
LSS (Lock Status Sensor)	COM-White (26AWG) NO-Green (26AWG) Bole locked NC-Blue (26AWG) Bole unlock

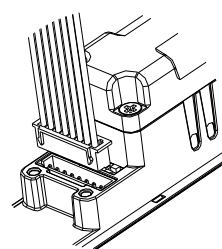

※ Caution: Please make sure the “+” and “-” wires are connected well and correctly before you apply a power source to the lock; Warning, Reverse polarity will make a short circuit and void products warranty.

VII. Power input setting

A. 12VDC input setting :

- Jumper setting as shown on below:

PIN-1 and PIN-2 closed

PIN-3 and PIN-4 closed

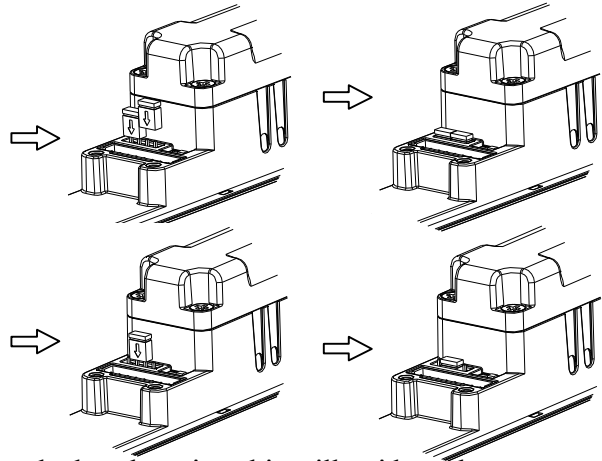
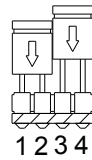

B. 24VDC input setting :

- Jumper setting as shown on below:

PIN-2 and PIN-3 closed

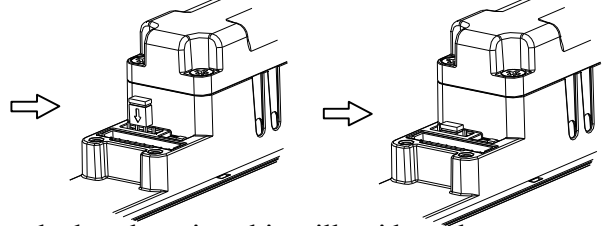
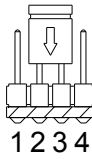

※ Caution: Please DO NOT connect the incorrect voltage to lock; otherwise, this will void products warranty.

VIII. Auto relocking timer setting: 4 sets of timer-0, 3, 6, 9 sec. - set up by 2-pin dip-switch and apply for following situations.

- Setting up the auto relocking timer: (Default Value: 0 sec.)

0 sec. 3 sec. (Exit switch time delay)



0 sec. 3 sec. (Door locking time delay)

6 sec. 9 sec. (Exit switch time delay)



6 sec. 9 sec. (Door locking time delay)

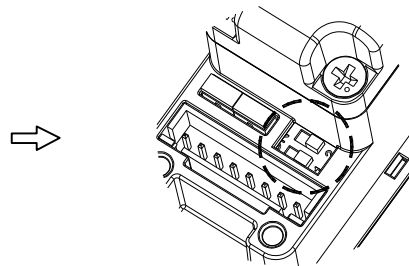

IX. Indicators-LED and BUZZER identification as following chart:

Indicators	LED	Buzzer
Waiting for locking	Red LED lights up	None
Door locking time delay	Green LED flashes once per second	None
Detecting lock	Red LED flashes once per second	None
Locked well	Green LED flashes once every two seconds	2 beeps per seconds
Fail to lock	Red LED flashes once per second for 10 seconds	1 beep per second for 10 seconds
Keeping locking	Red LED flashes once every two seconds for 30 seconds	1 beep every 2 seconds for 30 seconds
Forced entry (Alarm)	Green and Red LED's flash alternately every 0.5 sec. for 30 seconds	Keeps beeping for 30 seconds
Remote Release(Exit Switch)	Red LED flashes once per second for 3 seconds	1 beep per second

X. System functions: By logical program systems to control the bolt lock; It has auto-detective functions including bolt fixed position, door locking time delay, locked well and forced entry (alarm) and remote release (exit switch). (*)-See "I. Order Information"

- Standby** (Power on the system when door is open): If you close the door, the system will receive an induction and the time delay (0/3/6/9 sec.) will start to count, and then the auto-detective function will execute the following movements:

- However, the period of time delay, if door is opened, the bolt will automatically retract and the systems will return to standby.
- After a time delay (0/3/6/9 sec.), if door is closed, the bolt will automatically extend into the "Detecting lock" and may execute the following functions.
- After "Detecting lock" (or system received an induction of "Locked well"-(*)), the bolt will enter into an economical mode of electricity and locking will hold.

- (*). After "Detecting lock", if the bolt is out and not in the right position-"Fail to lock", the bolt will automatically retract in 10 seconds. Meanwhile, the users can see bicolor indicators or listen to the "warning buzzer" and push the door in the right position, the bolt will automatically extend into an economical mode of electricity and locking will hold.

- (*). In "Fail to lock", after 10 seconds, the bolt will enter into "Keeping locking" mode and re-lock every 30 seconds, The users can see bicolor indicators or listen to the "warning buzzer", users must open the door and then closed it again in the right position, the bolt will automatically extend into an economical mode of electricity and locking will hold.

2. Unlock (In locking, push the exit-switch) - "Remote Release": The bolt will automatically retract, after 3 seconds, if the door is closed, the time delay (0/3/6/9 sec.) will reset and count and execute the following functions.

(*3. Forced entry (Alarm): Indicates an error status or forced entry, the system can increase the thrust of the bolt and an alarm bell given (30 seconds).

XI. Installation Diagram:

A. Electric Bolt locks body

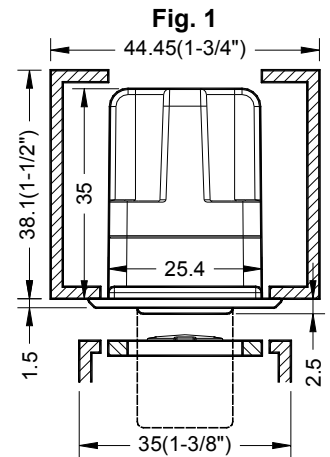
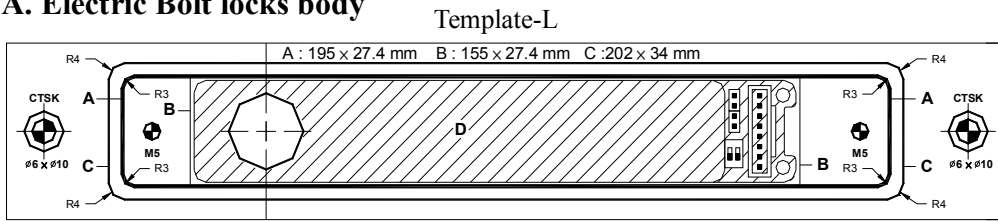

- Template-L: Paste up on the doorframe surface before making a mortise cutout.
(Template-L: Place-D is a lock body)

- Fig.1: The reference diagram of installation_1 (Typical-End view)
(Suitable for Door crack width > 3.0 mm)

- Fig.2: The reference diagram of installation_2 (Decorative plate-End view)
(Suitable for Door crack width > 1.5 mm)

- Fig.3: The reference diagram of installation_3 (Wood doorframe-Dimensions)
(Suitable for Door crack width > 1.5 mm)

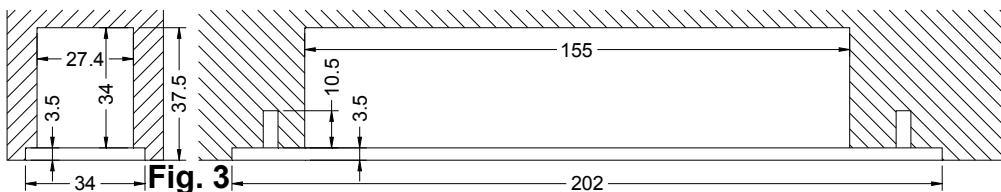
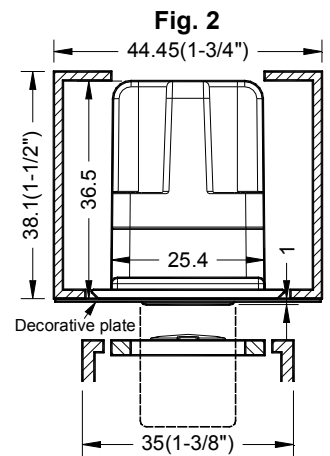

B. Striker plate

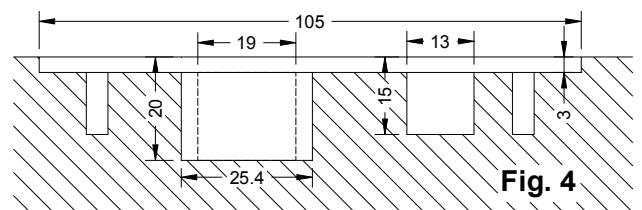
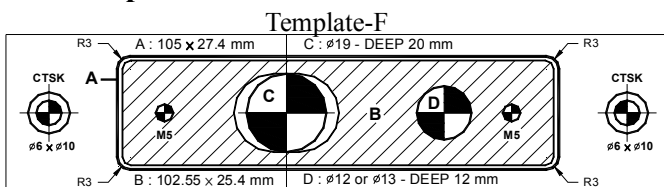

- Tem-F: Paste up on the door-side surface before making a mortise cutout.
(Tem-F: Place-B is a strike-plate)

- Fig.4: The reference diagram of installation_4
(Wood door-Dimensions)

- Fig.5: The reference diagram of installation_5
(Suitable for Metal door)

- Fig.6: The reference diagram of installation_6
(Suitable for Wood door)

- Fig.7: The reference diagram of installation_7
(Suitable for Heavy duty door)

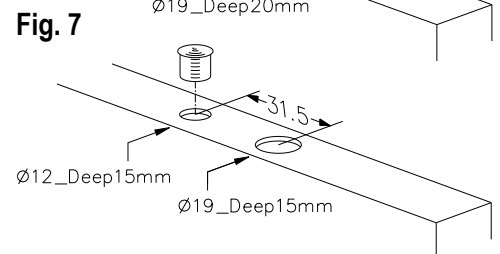
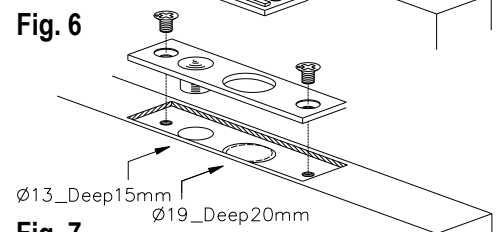
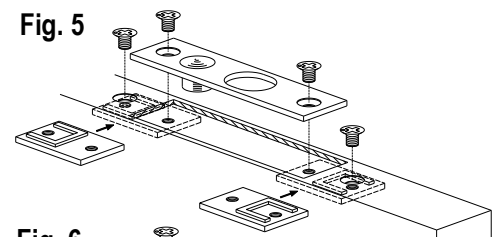

C. Dimension

Bolt	Ø15.8 mm	Bolt Depth	16 mm (5/8")	Lock Body	150L×25.4W×33D mm
Cover(Eaves)	200L×32W×1.5T mm	Face plate	193L×25.4W×2T mm	Striker plate	102.55L×25.4W×2T mm
Decorative plate	210L×44W×0.5T mm (Attached)				

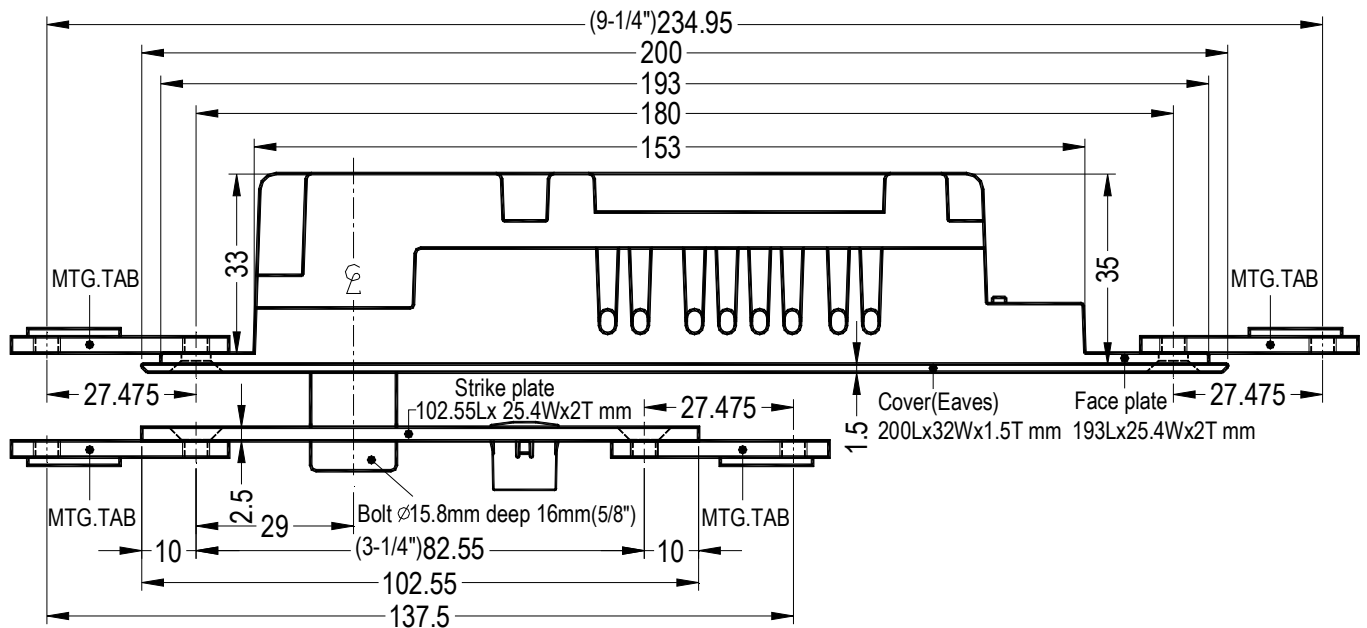

D. Installation Diagram

